

Data Sheet Wöhr Parking Platform 501

for lateral shunting

Suitable for condominium and office buildings.

Dimensions in cm. Load per parking place max. 2000 kg (max. wheel load 500 kg).

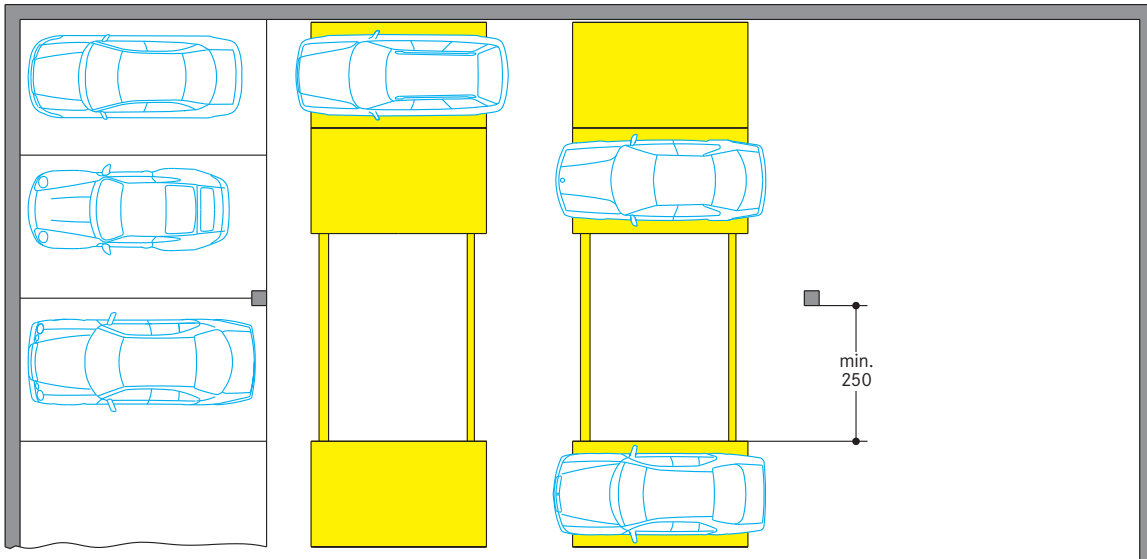
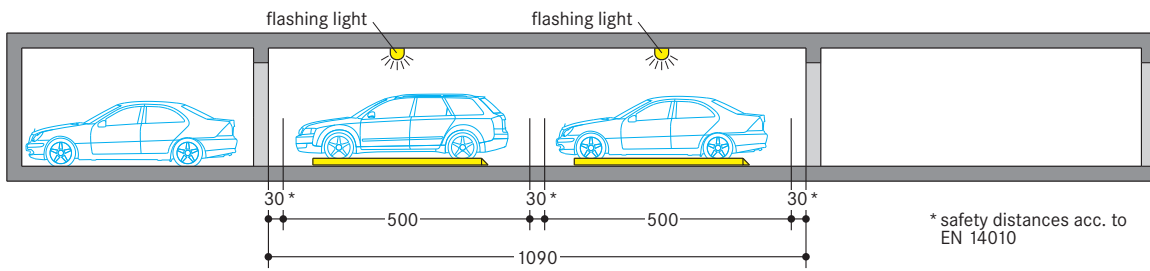

Arrangement with columns between the platform rows

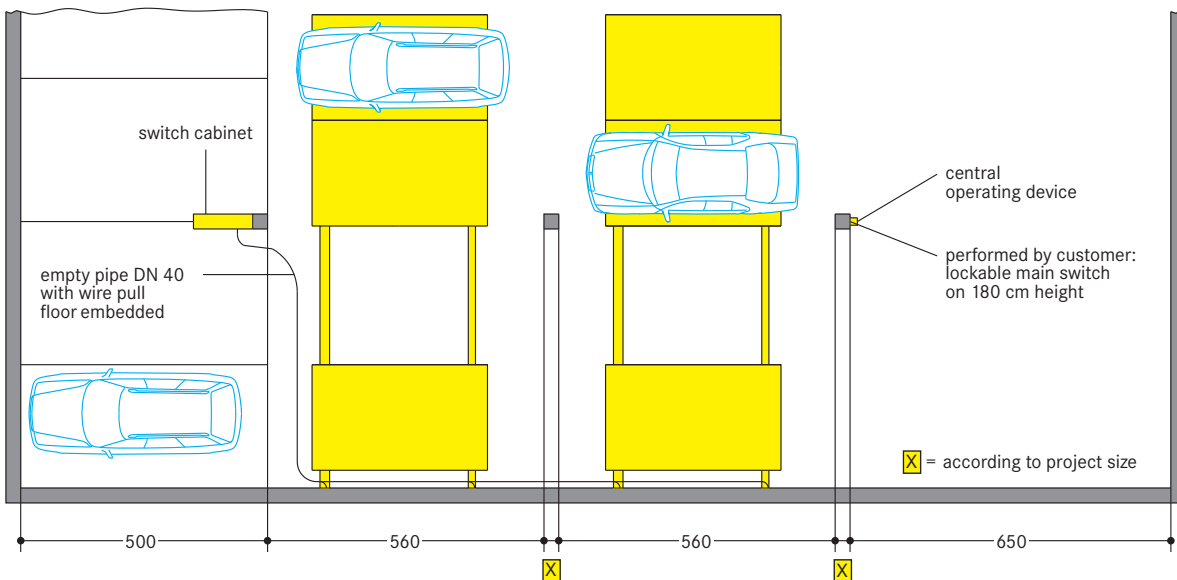

Notes

1. According to EN 14010 a 30 cm safety distance must be provided between the front and rear bumpers of cars being parked on the parking platforms and fixed parts of the environment, e.g. columns, or other cars. Considering a max. car length of 500 cm, the resultant distance between the columns must be 560 cm. This distance may only be reduced with the consequence of shortened max. car length or parking place length, or by introducing light barriers.
2. Each operating device can handle a number of car park places depending on project, parking arrangement and overview. Please consult WÖHR.
3. The operating device has to be installed at a place, where the whole shiftway can be viewed.
4. The manufacturer reserves the right to construction or model modifications and/or alterations. Furthermore, the right to any subsequent part modification and/or variations and amendments in procedures and standards due to technical and engineering progresses in the art or due to environmental regulation changes, are also hereby reserved.

Wohr Parking Systems Pvt. Ltd.

Gat No.1098, Urawade Road, Pirangut,

Tal. Mulshi, Dist. Pune - 412 115

Maharashtra, India +91 206 674 8848

www.wohrparking.in

We compact parking space



Track and floor details

The moving rail load of each platform wheel is max. 600 kg.

The evenness of the floor + screed must be achieved according to DIN 18202, table 3, line 2. After checking the floor + screed the levelling rails are mounted on top of the highest point.

The underlining and fixing of the levelling rails occurs at the intended fixing points. For the laying of the running and levelling rails a meter tear is to be attached permanently for every railway track by the client.

The screed is to be peeled off by the client on height of the levelling rails. Do not use mastic asphalt.

The running rails are fastened after placement of the screed with wood screws and plastic dowels. Evenness according to DIN 18202, table 3, line 3.

In the area of the railway track no expansion gap or building dividing gaps are allowed.

With later installations of the parking platforms, dependent on the ground evenness, an additional screed must be taken into consideration by the client. The decision of the steps occurs after a levelling.

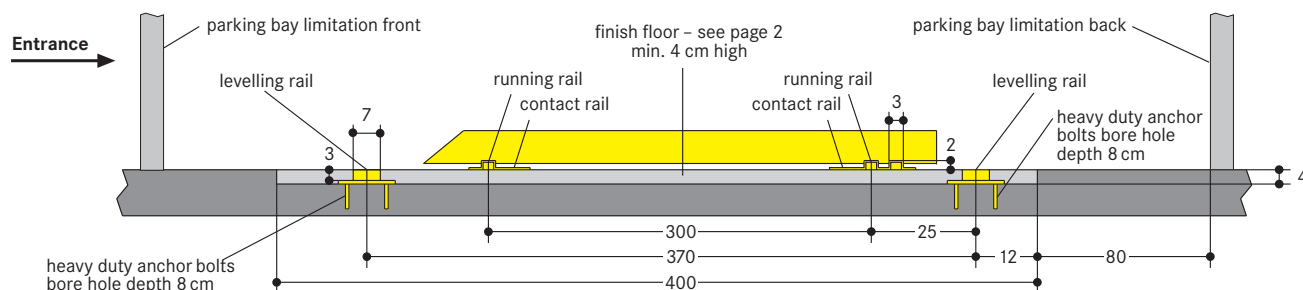

Drainage

According to EN 14010 the distance between finished floor and platform may not exceed 2 cm to avoid any danger to persons feet. No slope in the area of the parking platform.

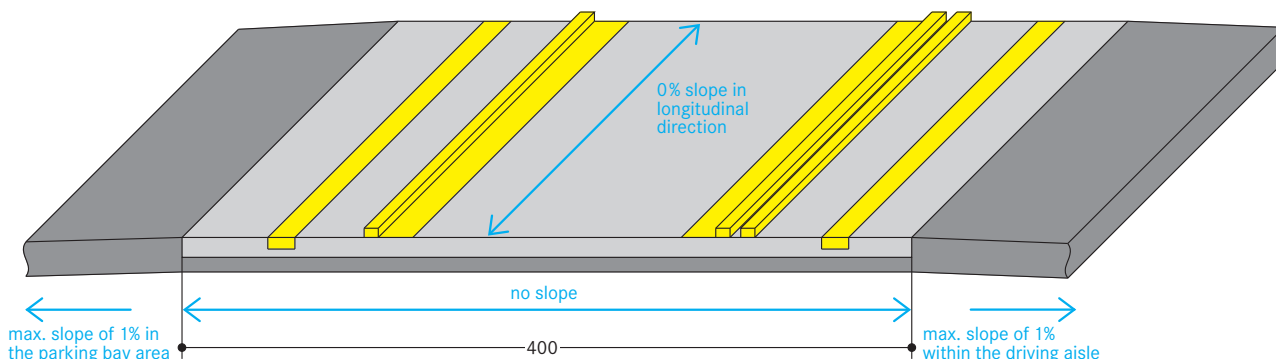

Control and supply of power

The current entry including lockable main switch must be mounted by the customer up to the control with 3 x 1,5 mm², 230 V (fuse 6 A slow blow according to DIN VDE 0100 part 430). (See page 1 the position of the lockable main switch.) The power is led to the parking platforms via the track system. (The supply is led) from the control system to the track system via cables which pass through empty pipes laid by

the client. The parking platform is selected at the operating device via a push button or a coded key. By means of the control system the parking platforms are moved in such a way that the access to the selected parking place is free. In addition, there is about 60–80 cm space on the left side of the parking place to get in and out of the car. On special request, this space can also be made available on the right side.

Noise

Ball bearings of the rollers provide a low sound level.

Maintenance

Regular maintenance by qualified personnel can be provided by means of an Annual Service Contract.

Protection against corrosion

Independent of a maintenance workings has to be carried out acc. to Wöhr Cleaning and Maintenance Instruction regularly.

Clean up galvanized parts and platforms of dirt and road salt as well as other pollution (corrosion danger)!

Garage must be always ventilated and deaired well.

Temperature

The installation is designed to operate between +5° and +40°C. Atmospheric Humidity: 50% at +40°C. If the local circumstances differ from the above please contact Wöhr.

Numbering of the parking spaces

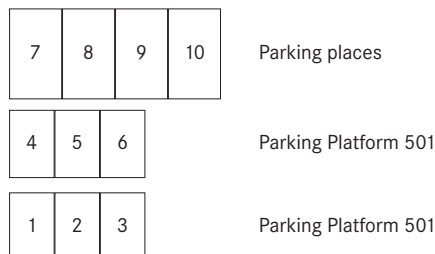

Different numbering of parking spaces is possible at extra cost (software changes are necessary).

Illumination

Illumination has to be considered acc. to local requirements by client.

Product liability

Wöhr does not take any liability for damages due to squeezing danger because the evenness tolerances are not fulfilled. The distance between the lower edge of the platform and the finished floor may not exceed 2 cm.

Conformity test

All our systems are checked according to EC machinery directive 2006/42/EC and EN 14010.

Fire safety

Each and every fire safety requirement and all possible mandatory item(s) and equipment(s) (fire extinguishing systems and fire alarm systems, etc.) are to be provided by the customer.

Dimensions

All dimensions are in cm.

■ Dimensions of Parking Platform

Dimensions in cm. Scale 1:50

■ Section

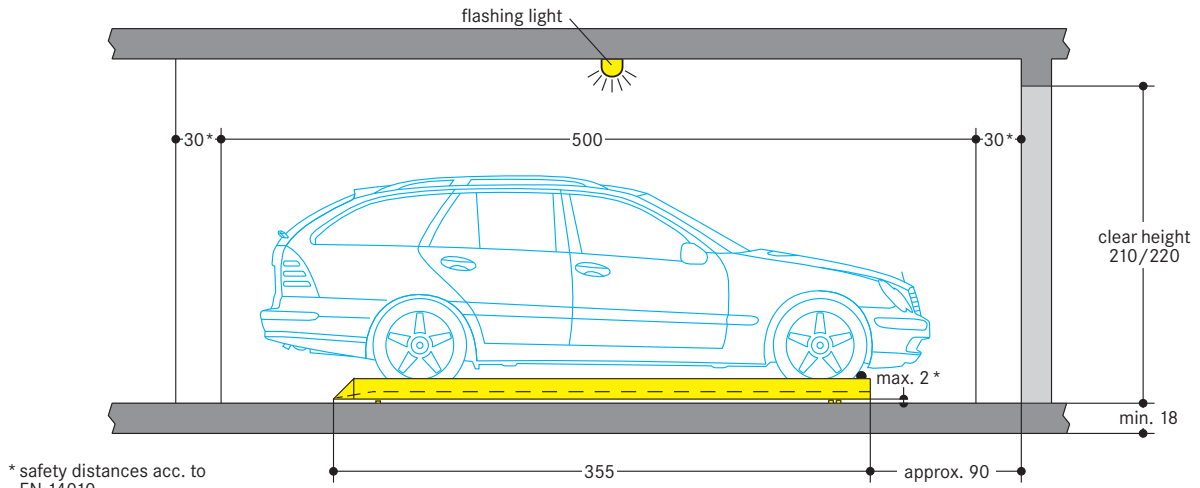

■ Top view

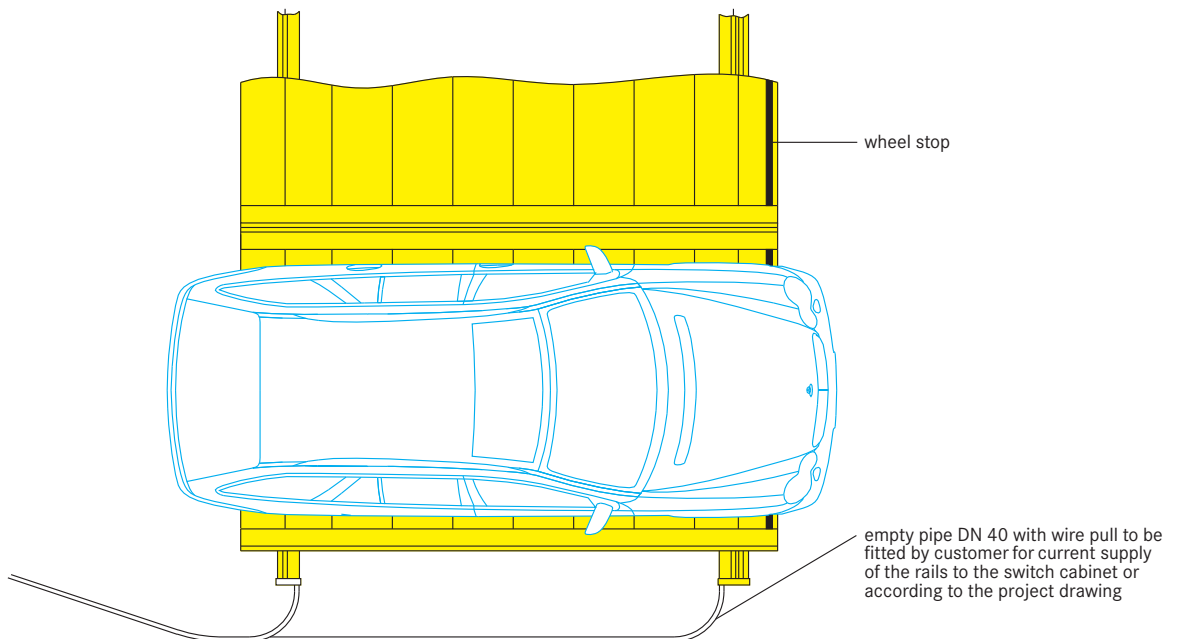

■ Rear view

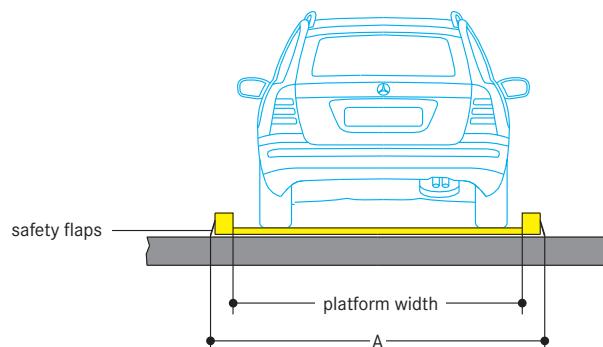

dimension A	gives clear platform width
226	197
236	207
246	217
256	227

We recommend a minimum platform width of at least 207 cm.

■ Clearance profile (standard saloon/estate car)

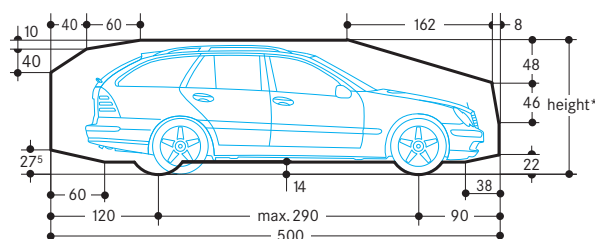

* max. car height: please note the conditions of the building

Evenness and tolerances

According to EN 14010 the danger of trapping between nonparallel platforms edges and the ground has to be prevented. The distance between the lower flange of the platforms and the garage ground must therefore not exceed 2 cm.

To adhere to the safety regulations and to get the necessary even ground, the tolerances of evenness to DIN 18202, table 3, line 3, must not be exceeded. Therefore exact levelling of the ground by the client is essential.

Abstract from DIN 18202, table 3

column	1	2	3	4	5	6
line	reference	Vertical measurements as limits in mm with measuring points distances in m to*				
		0,1	1	4	10	15
2	Unfinished to surface of covers, subconcrete and subsoils for higher demands, e.g. as foundation for cast plaster floor, industrial soils, paving tiles and slabstone paving, compound floor paving. Finished surfaces for minor purposes, e.g. warehouses, cellars	5	8	12	15	20
3	Finished grounds, e.g. floor pavement serving as foundation for coverings. Coverings, tile coverings, PVC flooring and glued coverings.	2	4	10	12	15

* Intermediate values are to be taken out the diagram and must be rounded-off to mm.

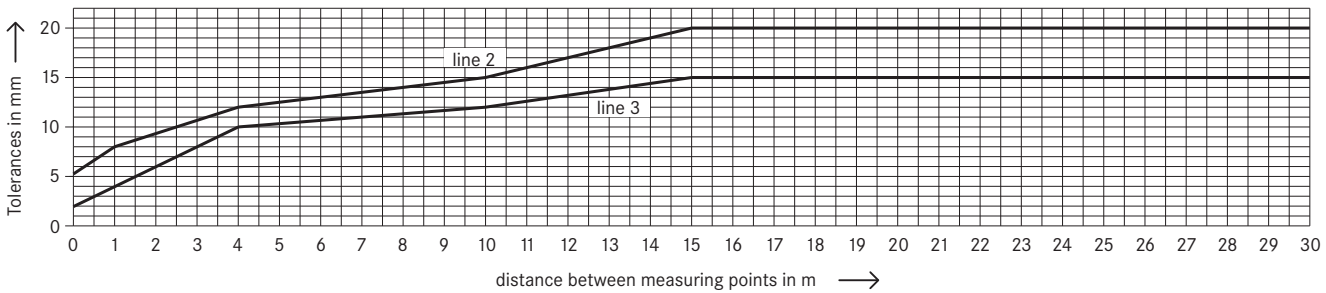

Measuring points

The evenness of a surface is checked independently of its position and slope by bore hole gauges between two check points on the surface. Wöhr normally make a random test using single measurements in case of obviously inaccurate surfaces.

For uniform examination of the evenness of the ground surface the following points are defined as measuring and check points:

- for surface recess
- for finished floor

a) Layout for surface recess width 400 cm

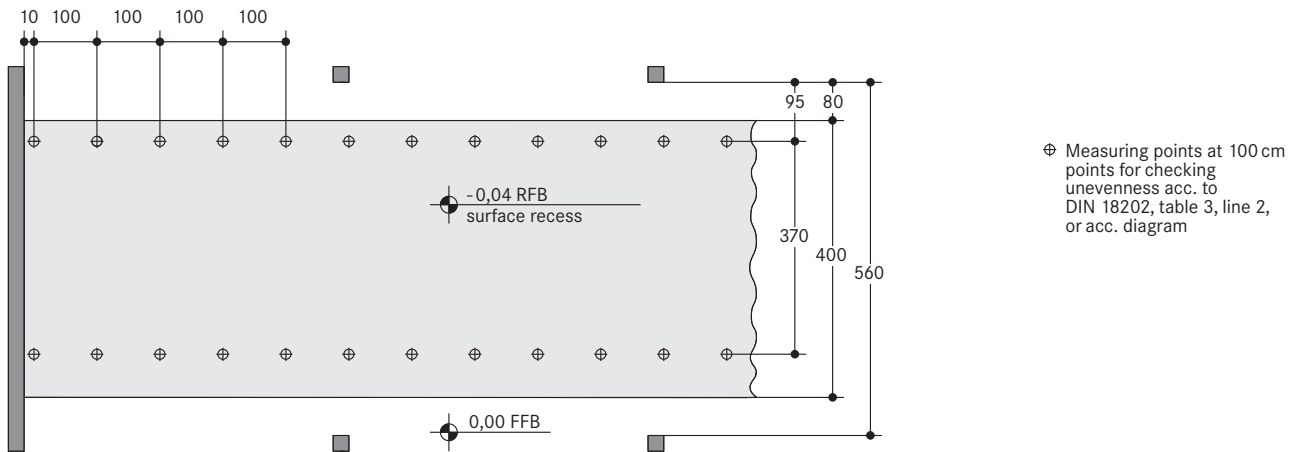

b) Layout for finished floor after placing floor pavement

