

# Surface Protection 2018 for WOHR Parking Systems



## 1 General Remarks

### 11 Classification of parking systems

Wohr Parking Systems are machines as defined by the machine directive 2006/42/EC, Appendix 1 and the EN14010.

The surface protection – hereafter described in detail – is based on functional and technical assessments of the individual parts in order to take into account necessary, commonly encountered corrosive individual loading in accordance with DIN EN ISO 12944-1. The corrosion protection is therefore defined in various ways.

**The classification of the parking systems in accordance with DIN EN ISO 12944-2 states:**

**Corrosivity category C3 moderate (inside: production rooms with high degree of damp and some air pollution or outside: urban and industrial atmosphere, moderate pollution by sulphur dioxide. Coastal areas with low salt content). Note: C3 applies to structural elements located above drive-in levels.**

**Corrosivity category C2 low (interior: unheated buildings where condensation may occur, e.g. depots, sports halls). C2 applies to all moving parts such as gear wheels, gear racks, chains and pinion located either above or below the entrance levels.**

#### Planning notes:

In our capacity as manufacturer of parking systems, we cannot be aware of the site conditions - neither of the installation site in question, nor of its surroundings. We are therefore not in position to assess whether any other corrosivity categories may be applicable to the installation location in terms of corrosion protection.

In the event that the environmental requirements relating to the installation site are **higher** than those specified in this datasheet, then the architect/investor/ordering party either need to take a shorter protection duration term of the relative surface protection issues into account. The measures proposed in the section "**Damage minimisation**" can also be implemented by the customer for ventilation or pit drainage.

Wherever necessary, the architect/investor and/or ordering party are required to reach a decision and to notify us in the event that corrosivity categories C3 and/or C4 are to be considered as inapplicable. If we are not notified to this effect then we shall, in principle, proceed with delivery per the contents of this datasheet.

### 12 Length of protection/repair

The length of protection in compliance with DIN EN ISO 12944-1 is medium (M) 5 –15 years. The length of protection does not constitute a "warranty period". The length of protection is a technical term designed to help the client stipulate a repair programme. The warranty period is generally shorter than the length of protection. A repair may well be required earlier than foreseen by the length of protection due to fading, pollution, wear, abrasion or other reasons (cf. DIN EN ISO 12944-5, Itm. 5.5). This also does not constitute a defect covered by the warranty.

### 13 Coatings systems

Coatings with powder-based paints have been tested as medium on the basis of DIN EN ISO 12944-6 C 3. The requirements were fulfilled and verified in batteries of tests.

Coatings with zinc in compliance with DIN EN 10326 and DIN EN ISO 1461.

### 14 Rust level

In compliance with DIN EN ISO 4628-3, we guarantee a rust Level of Ri 3 until expiry of agreed warranty period on coated surfaces of the side beams and middle panels under the condition that parking system is properly cared for and maintained.

Partial damage of the coating (up to 1% of the reference surface) can be possibly caused by mechanical, climatic and chemical influences. The function and safety of the parking system is not impaired by this, so that coating damage does not constitute grounds for complaint or a defect covered by the warranty, provided that the rust degree Ri 3 is not crossed within the guarantee term at the driving area of the parking systems.

### 15 Cleaning and Maintenance

Please refer to the data sheet "Cleaning and Maintenance of Wohr Parking Systems". As part of our service activities our local Partner offers cleaning and maintenance measures against surcharge for car parking systems of WÖHR.

### 16 Damage minimisation (to be performed by the customer)

Premature corrosion damages to the protection coating can furthermore be prevented by:

- limiting exposure to dampness and humidity (e.g. by removing the snow clumps from vehicle wheel housings)
- seeing to appropriate site aeration (i.e. to prevent the relative atmospheric humidity levels from reaching < 80%, particularly in the colder months of the year)
- performing regular and appropriate cleaning of both the top surface of the platform and of the pit floor (please consult the cleaning and maintenance section herein)
- draining away any water accumulating in the pit and by removing dirt and debris from the pit sump and/or from the pit drainage channels
- the regular and appropriate reconditioning of any visible surface alterations

### 17 Wear and tear

Through utilization, abrasion and usage a natural wear occurs on the platform upper side, this does not constitute a warranty defect.

### 18 Warranty periods

Warranty periods are guaranteed according to the offer conditions.

### 19 Notes

The manufacturer reserves the right to construction or model modifications and/or alterations. Furthermore, the right to any subsequent part modification and/or variations and amendments in procedures and standards due to technical and engineering progresses in the art or due to environmental regulation changes, are also hereby reserved.

**WOHR Parking Systems Pvt. Ltd. | Pune India**

☎ +91 20 66748848 | [info@wohrparking.in](mailto:info@wohrparking.in) | [www.wohrparking.in](http://www.wohrparking.in)

## 2 Corrosion protection PARKLIFT, COMBILIFT

### 21 Platform corrosion protection

For systems: PARKLIFT 440, 411, 421, Combilift 551, 552

- **Driving metal sheets, drive on sheets, cover plates and, if applicable platform extension**  
Galvanised as per DIN EN 10326 with approx. 20 µm zinc layer.
- **Side panels**  
Galvanised as per DIN EN 10326 with approx. 20 µm zinc layer.
- **Middle panels**  
Galvanised as per DIN EN 10326 with approx. 20 µm zinc layer.
- **Cross beam**  
Single units: partially galvanised as per DIN EN 10326 with approx. 20 µm zinc layer, partially hot-dipped galvanised as per DIN EN ISO 1461 with approx. 55 µm zinc layer.  
Double units: hot-dipped galvanised as per DIN EN ISO 1461 with approx. 55 µm zinc layer.
- **Screws, washer and nuts for the installation of the driving metal sheets**  
Sheet mounting for the side and central panels of self-channelling screws, Washers and nuts electrolytically galvanised as per DIN 50961, approx. 5–8 µm zinc layer.

### 22 System-relevant corrosion protection

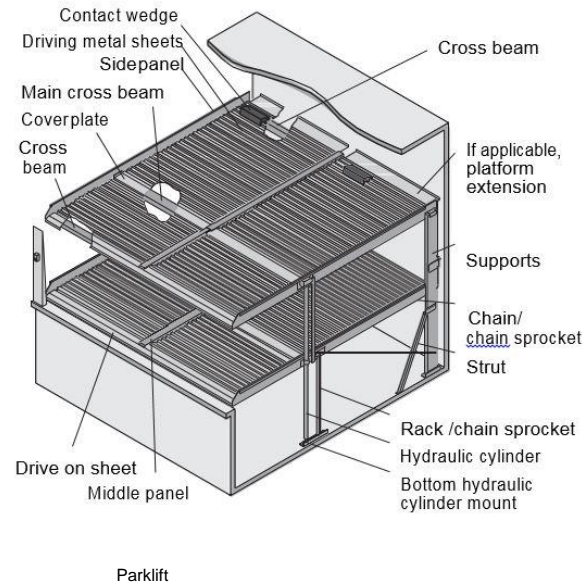

Parklift

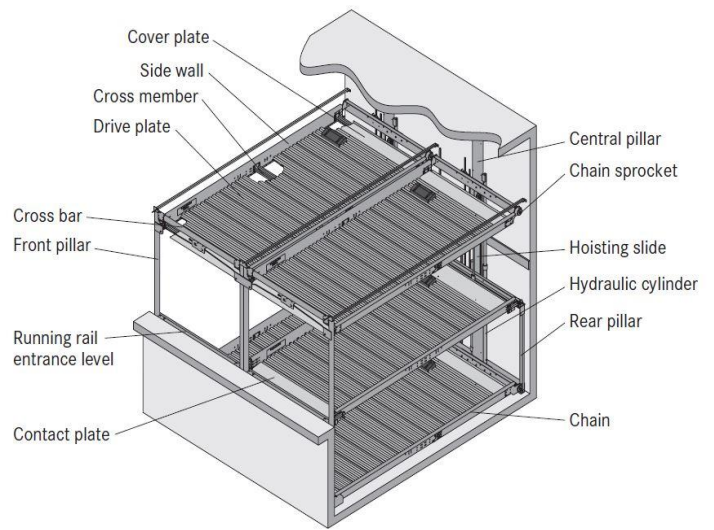

Combilift

	440	411	421	551	552	543
Support / Pillar	■	■	■	●	●	●
Strut support	□	△	■	■		
Hydraulic cylinder	◐	◐	◐	◐	◐	◐
Torsion bar/synchro shaft	●	●	●		●	
Chain sprocket/pinion	△	△	△	△	△	△
Chain/rack	▲	▲	▲	▲	▲	▲
Dowel Pin for unit mount	△	△	△	△	△	△
Screws, nuts, washers	△	△	△	△	△	△
Hydraulic tube, hydraulic screw connections, bolts	△	△	△	△	△	△
Lower hydraulic cylinder mount	■	■	■	■	■	■
Mounts support/side wall	■	■	■	■	■	■
Mounts torsion bar/side wall	●	●	●		●	
Mounts hydraulic cylinder/side wall	●	●	●	●	●	●
Railing Bars/Tubes	◐					
Railing posts	□					
Solenoid valves	Alu	Alu	Alu	Alu	Alu	Alu
Hydraulic Power Pack	●	●	●	●	●	●

### Symbol Legend

△	galvanised as per DIN 50961, zinc layer approx. 5–8 µm
□	hot-dipped galvanised as per EN 10327, approx. 20 µm zinc layer (continuously galvanised)
■	hot-dipped galvanised as per DIN EN ISO 1461, approx. 55 µm zinc layer (localised layer thickness as minimum value)
▲	black, greased
▣	Zinc lamellar coating
○	Sand blasted (purity grade SA 2.5), primer coat approx. 40 µm, covering coat approx. 80 µm
◐	Painted with one-coat paint, thickness of layer approx. 80 µm, colour yellow (RAL 1003)
●	Stained, greased plate, bath-cleaned phosphated, powder-coated on epoxy resin basis, Layer thickness approx. 60–80 µm, colour gravel grey (RAL 7032)